

Model IBCRS-2-04-LC

37" HIGH BACKBAR WITH DRAWERS

PROJECT: _____

ITEM NUMBER: _____ **QTY:** _____

37" HIGH BACKBAR WITH DRAWERS

MODELS

REMOTE UNITS

- IBCRR-1-02 IBCRR-3-06
- IBCRR-2-04 IBCRR-4-08

SELF-CONTAINED UNITS

- IBCRS-1-02 IBCRS-3-06
- IBCRS-2-04 IBCRS-4-08

MODEL CONFIGURATION

Example: **IBCRS-2-04-RC**

IBC - - -

1
 2
 3
 4

STANDARD FEATURES

- All Heliarc welded construction
- All 18-Gauge, Type 304 stainless steel interior and exterior
- Easy clean with 3/8 radius interior corners
- CFC-Free "shot-in-place" insulation
- Heavy duty breaker strip 'foam-locked' in position
- Two stainless steel pans per section
- Pre-wired internal flexible conduit to a single point connection
- Blower coil fully equipped with expansion valve, thermostat and solenoid valve (on remote units)
- Self-contained units supplied with compressor compartment with condensing unit, condensate expansion pan, cord and plug
- 14-Gauge, stainless steel drawer track systems with 2" skate wheels
- Polished heavy duty door pulls

1	RR = Remote RS = Self-Contained
2	1 = One Section (Two Drawers) 2 = Two Sections (Four Drawers) 3 = Three Sections (Six Drawers) 4 = Four Sections (Eight Drawers)
3	02 = Two Drawers (One Section) 04 = Four Drawers (Two Sections) 06 = Six Drawers (Three Sections) 08 = Eight Drawers (Four Sections)
4	(On Self-Contained Units) LC = Condensing Compartment on Left Side RC = Condensing Compartment on Right Side

OPTIONS

- CL** 6" High S/S Adjustable Legs
- CS4** 4" Heavy Duty Casters
- CS6** 6" Heavy Duty Casters
- DT** Dual Temp
- F** Freezer
- KR** Kick Rail
- RW** Red Wine
- ST** Stainless Steel Top
- WW** White Wine
- M** Modified - Custom



INFINITY KITCHEN PRODUCTS, INC.

7750 Scout Ave. • Bell Gardens, CA 90201
 Toll Free: (866) 349-0005 • Ph: (562) 806-5771 • Fax: (562) 806-6771
 infinitystainless.com • customerservice@infinitystainless.com

Proudly Made in America

37" HIGH BACKBAR WITH DRAWERS

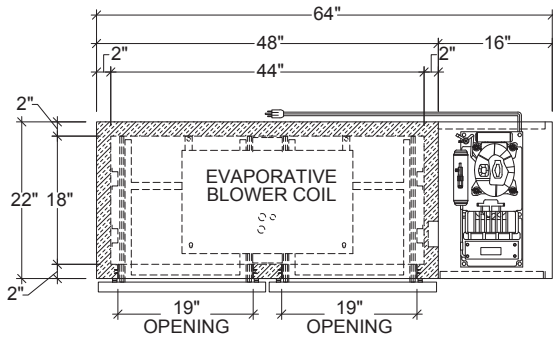

PLAN VIEW

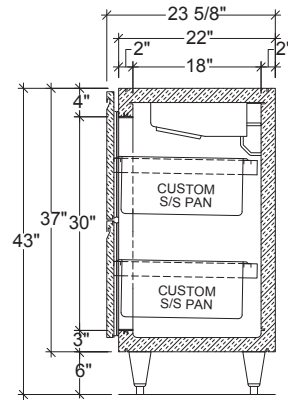

STANDARD SECTION

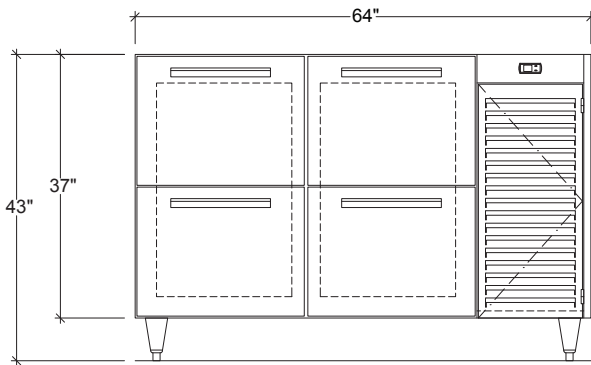

ELEVATION

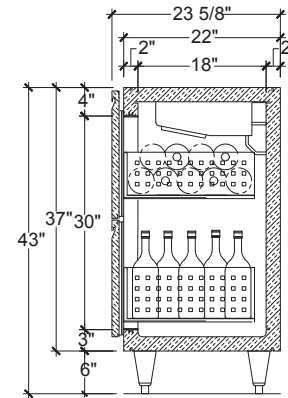

WINE STORAGE SECTION

MODEL SHOWN: IBCRS-2-04

REMOTE UNITS

MODEL	LENGTH	VOLTS	TOTAL AMPS	MIN. CIRCUIT BKT.	PHASE	MAX CIRCUIT BKT.	BTU'S	WEIGHT
IBCRR-1-02	25"	115v	1.3	1.6A	1ph	15A	461	292
IBCRR-2-04	48"	115v	1.8	2.2A	1ph	15A	966	370
IBCRR-3-06	72"	115v	2.2	2.8A	1ph	15A	1493	430
IBCRR-4-08	96"	115v	2.7	3.4A	1ph	15A	2064	500

SELF-CONTAINED UNITS

MODEL	LENGTH	H.P	VOLTS	TOTAL AMPS	MIN. CIRCUIT BKT.	PHASE	MAX CIRCUIT BKT.	BTU'S	WEIGHT
IBCRS-1-02	41"	1/3 HP	115v	8.2	10.2A	1ph	15A	461	520
IBCRS-2-04	64"	1/3 HP	115v	8.7	10.9A	1ph	15A	966	630
IBCRS-3-06	88"	1/3 HP	115v	9.1	11.4A	1ph	15A	1493	690
IBCRS-4-08	112"	1/3 HP	115v	9.6	12.0A	1ph	15A	2064	1030

INFINITY KITCHEN PRODUCTS, INC.

7750 Scout Ave. • Bell Gardens, CA 90201
 Toll Free: (866) 349-0005 • Ph: (562) 806-5771 • Fax: (562) 806-6771
 infinitystainless.com • customerservice@infinitystainless.com

*Proudly Made
 in America*