

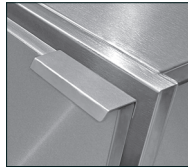

Model IBL-2D-SSD-LR-CL-ST

Edge Mount
Door Pull
(optional)



STANDARD FEATURES

- All Heliarc welded construction
- All 18-Gauge, Type 304 stainless steel interior and exterior
- Door actuated interior light(s)
- Two Stainless steel wire shelves per section
- Magnetic door gasket
- Pre-wired internal flexible conduit to a single point connection
- Polished heavy duty door pulls
- Door Lock(s)



INFINITY KITCHEN PRODUCTS, INC.

7750 Scout Ave. • Bell Gardens, CA 90201
 Toll Free: (866) 349-0005 • Ph: (562) 806-5771 • Fax: (562) 806-6771
 infinitystainless.com • customerservice@infinitystainless.com

PROJECT: _____
ITEM NUMBER: _____ **QTY:** _____

32" HIGH DRY CABINET

32" HIGH DRY CABINET

MODELS

- IBL-1D
- IBL-3D
- IBL-2D
- IBL-4D

MODEL CONFIGURATION

Example: **IBL-2D-SSD-LR**

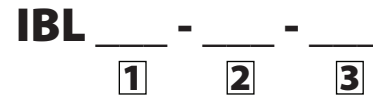

1	1D = One Door 2D = Two Doors 3D = Three Doors 4D = Four Doors
2	SSD = Stainless Steel Door GD = Glass Door LD = Laminated Door (Pricing Varies) FLD = Field Laminated Door (Plywood Door) PC = Powder Coated Door (Pricing Varies)
3	(Door Hinged Starting on the Left) L = Left Hinged R = Right Hinged

OPTIONS

- CL** 6" high stainless steel adjustable legs
- CS4** 4" Heavy Duty Casters
- CS6** 6" Heavy Duty Casters
- EDP** Edge Mount Door Pull
- KR** Kick Rail
- ST** Stainless Steel Top
- M** Modified - Custom

Proudly Made
in America

32" HIGH DRY CABINET

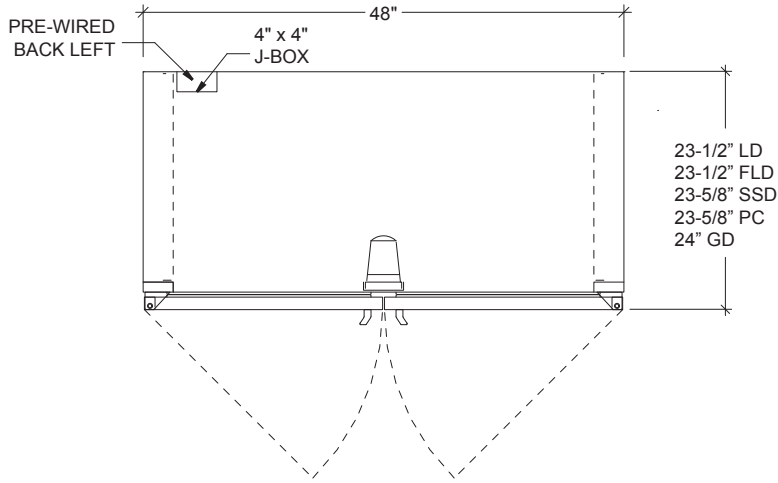

PLAN VIEW

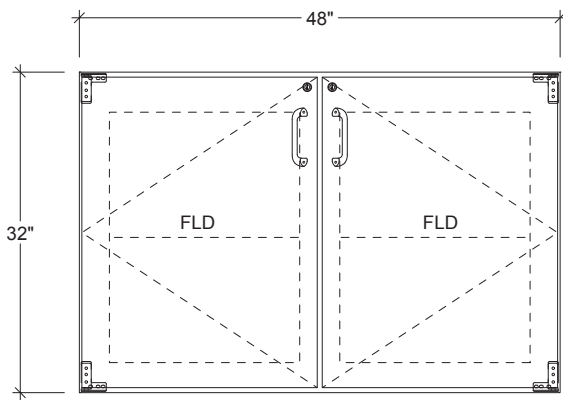

TYPICAL ELEVATION

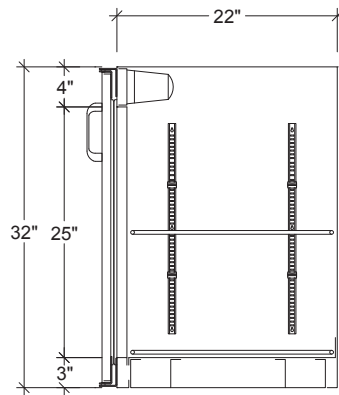

SECTION

MODEL SHOWN: IBL-2D-FLD-LR

32" HEIGHT					
MODEL	LENGTH	VOLTS	AMPS	PHASE	WEIGHT
IBL-1D	25"	115v	1.3	1ph	292
IBL-2D	48"	115v	1.7	1ph	370
IBL-3D	72"	115v	2.3	1ph	430
IBL-4D	96"	115v	3.7	1ph	500

INFINITY KITCHEN PRODUCTS, INC.

7750 Scout Ave. • Bell Gardens, CA 90201
 Toll Free: (866) 349-0005 • Ph: (562) 806-5771 • Fax: (562) 806-6771
 infinitystainless.com • customerservice@infinitystainless.com

*Proudly Made
 in America*