

Model IPRS-2-04-RC-CL

32" PLATE SHELF WITH DRAWERS

PROJECT: _____

ITEM NUMBER: _____ **QTY:** _____

32" PLATE SHELF WITH DRAWERS

MODELS

REMOTE UNITS

- IPRR-1-02 IPRR-2-04 IPRR-3-06

SELF-CONTAINED UNITS

- IPRS-1-02 IPRS-2-04 IPRS-3-06

STANDARD FEATURES

- All Heli-arc welded construction
- All 18 gauge type 304 stainless steel interior and exterior
- CFC-Free "shot-in-place" insulation
- Easy clean 3/8" radius interior corners
- Polypropylene breaker strip is foamed-locked in-place
- High compression magnetic vinyl door and gasket
- Drawers each accommodates two full size pans side-by-side
- Pre-wired electrical conduit is internally installed within inner and outer walls
- Blower coil with expansion valve, thermostat and solenoid valves (on remote units)
- Self-contained units supplied with compressor compartment with condensing unit, condensate expansion pan, cord and plug
- 14 gauge stainless steel drawer track system with 2" skate wheels
- Heavy duty stainless steel night cover
- Patent pending, air cooled pan rail

MODEL CONFIGURATION

Example: **IPRS-2-04-RC**

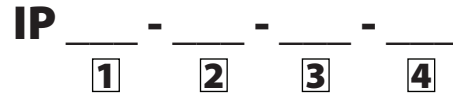

1	RR = Remote RS = Self-Contained
2	1 = One Section (Two Drawers) 2 = Two Sections (Four Drawers) 3 = Three Sections (Six Drawers)
3	02 = Two Drawers (One Section) 04 = Four Drawers (Two Sections) 06 = Six Drawers (Three Sections)
4	(On Self-Contained Units) LC = Condensing Compartment on Left Side RC = Condensing Compartment on Right Side

OPTIONS

- CL** 6" High S/S Adjustable Legs
- CS4** 4" Heavy Duty Casters
- CS6** 6" Heavy Duty Casters
- DT** Dual Temp
- F** Freezer
- M** Modified - Custom



INFINITY KITCHEN PRODUCTS, INC.

7750 Scout Ave. • Bell Gardens, CA 90201
 Toll Free: (855) 737-4688 • Ph: (562) 806-5771 • Fax: (562) 806-6771
 infinitystainless.com • customerservice@infinitystainless.com

Proudly Made in America

32" PLATE SHELF WITH DRAWERS

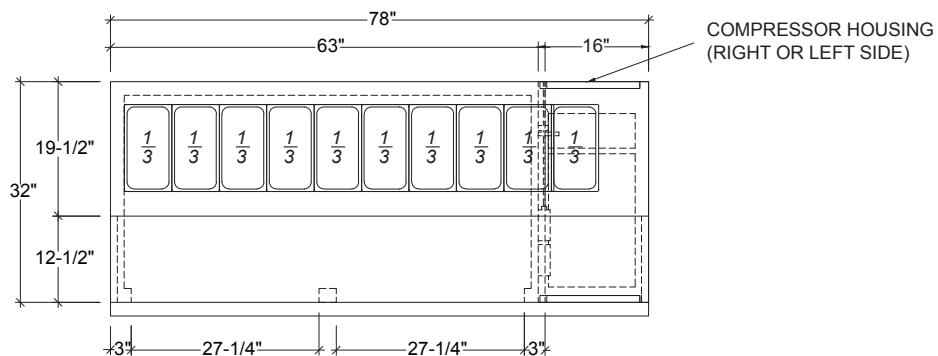

PLAN VIEW

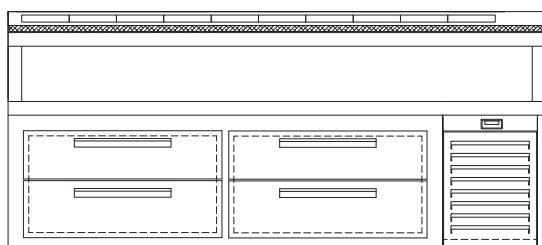

ELEVATION

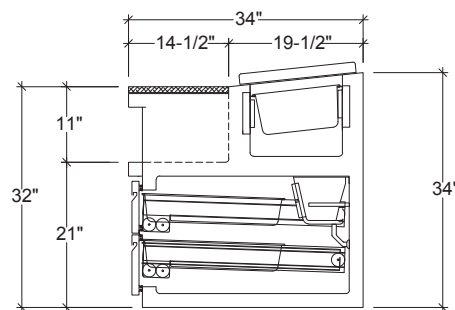

DRAWER SECTION

MODEL SHOWN: IPRS-2-04-RC

REMOTE UNITS

MODEL	LENGTH	VOLTS	TOTAL AMPS	MIN. CIRCUIT BRACKET	PHASE	MAX CIRCUIT BRACKET	BTU'S	WEIGHT
IPRR-1-02	33-1/4"	115v	1.4	1.8A	1.4ph	15A	1312	325
IPRR-2-04	63"	115v	2.7	3.4A	2.7ph	15A	3029	455
IPRR-3-06	92-3/4"	115v	4.0	5.0A	4.0ph	15A	4908	575

SELF-CONTAINED UNITS

MODEL	LENGTH	H.P	VOLTS	TOTAL AMPS	MIN. CIRCUIT BRACKET	PHASE	MAX CIRCUIT BRACKET	BTU'S	WEIGHT
IPRS-1-02	49-1/4"	1/3 HP	115v	8.5	10.6A	1ph	15A	1879	555
IPRS-2-04	79"	1/3 HP+	115v	9.8	12.2A	1ph	15A	3779	720
IPRS-3-06	108-3/4"	1/2 HP	115v	13.9	17.4A	1ph	20A	5433	830

INFINITY KITCHEN PRODUCTS, INC.

7750 Scout Ave. • Bell Gardens, CA 90201
 Toll Free: (855) 737-4688 • Ph: (562) 806-5771 • Fax: (562) 806-6771
 infinitystainless.com • customerservice@infinitystainless.com

Proudly Made
 in America